

Transfer Gear Pumps Type KF
Noise Optimized

Construction of the Gear Pumps Type KF

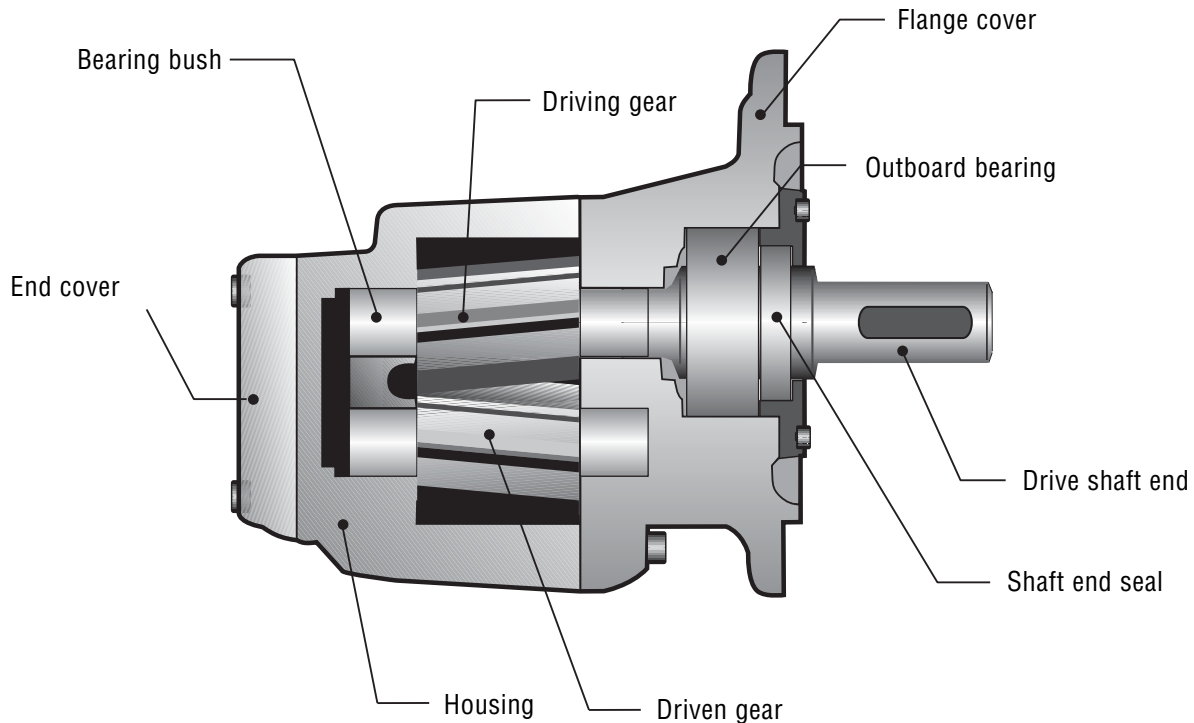

General

KRACHT pumps type **KF** are external gear pumps that work in accordance with the positive-displacement principle. Two gears work together creating negative pressure during rotation in the pump intake (suction side) so that the fluid to be conveyed can flow in.

Fluid transport ensues by means of trapping fluid, in the tooth gaps along the walls of the gear chamber. In the pump exhaust (pressure side), submergence of the teeth in the filled tooth gaps displaces a corresponding volume. The so-called geometric volumetric displacement V_g is displaced per gear rotation; this is a value that is specified in the technical documentation as Rated Quantity V_{gn} for designation of the pump size. The fluid quantity displaced does not actually correspond with the theoretical value, and is reduced as a result of losses due to the necessary clearances. The lower the level of operational pressure and the higher the degree of viscosity, the lower the losses are.

The lateral play between the gear wheel fore-part and the housing fore-part is measured such that the permissible operational pressure is safely controlled and losses are at the lowest possible level.

Gear pumps are regenerative in broad margins. The working pressure required for overcoming these resistances is set only after specification of external loads, e.g., such as pump lifts, outflow resistances, conduit elements, etc.

The noise optimized pumps of the KF Series are primarily designed for the transport of mediums with an increased share of air, whereby both normal operation and vacuum operation are possible. In applications with no air content in the medium, this type of utilization is not advisable since in such case the noise reduction does not take effect. In these cases, the targeted application of noise reduction elements and also flexible hoses are recommended for achieving noise reduction. Our Sales Engineers are happy to advise you!

Construction of the Gear Pumps Type KF

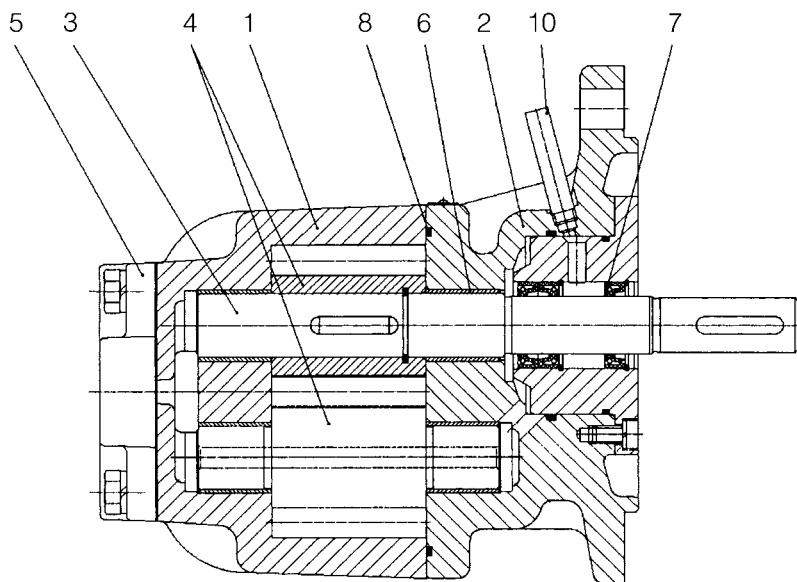

Fig. 1 **Pump without outboard bearing, special code 94**

- 1 Housing
- 2 Flange cover
- 3 Driving shaft
- 4 Gears
- 5 End cover
- 6 Bearing bush
- 7 Shaft end sealing
- 8 O-Ring
- 10 Connection pipe

Construction

The following illustrations show the construction of the KF models described on Page 2. Models **196** and **197** are designed for the transport of air-content transmission oils, therefore for application as a lubricating oil pump in ship gears and stationary gears. Special construction measures prevent the otherwise normal noise increase associated with air-content transmission oils and high degrees of negative pressure. The noise levels do not exceed or only negligibly exceed the measurement valued with non-air-content oils. A shift in the noise spectrum to higher, unpleasant frequencies also does not occur.

Pumps with the special code **197** are built as mounted pumps or pumps in combination with an electronic motor. The mounted pump (Fig. 2) is equipped with an outboard bearing for the absorption of radial forces like the type that appear when using a floating pinion.

The pump in combination with an electronic motor (Fig. 3) has no outboard bearing and must be driven by means of a flexible coupling.

Mounted pump and electronic motor are sealed at the shaft end by a rotary shaft seal.

The pumps with the special code **196** are built as mounted pumps both with (Fig. 4) and without an outboard bearing. This model has no seal at the shaft end, making it possible to operate it with pressure on the suction side. The accruing leakage oil is fed off into the gear space.

The pumps with the special code **94** (Fig. 1) are designed for deployment in vacuum facilities for the degassing and cleaning of oils. These pumps are built as pumps in combination with an electronic motor and have no outboard bearing for the absorption of external radial forces. At this version, a triple sealing with quench is used as shaft sealing. The middle shaft sealing is mounted for suction operation.

Construction of the Gear Pumps Type KF

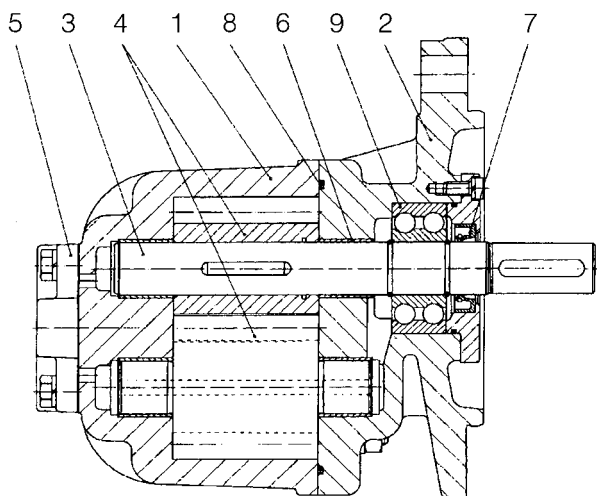

Fig. 2 **Pump with outboard bearing, special code 197**

- 1 Housing
- 2 Flange cover
- 3 Driving shaft
- 4 Gears
- 5 End cover
- 6 Bearing bush
- 7 Shaft end sealing
- 8 O-Ring
- 9 Outboard bearing

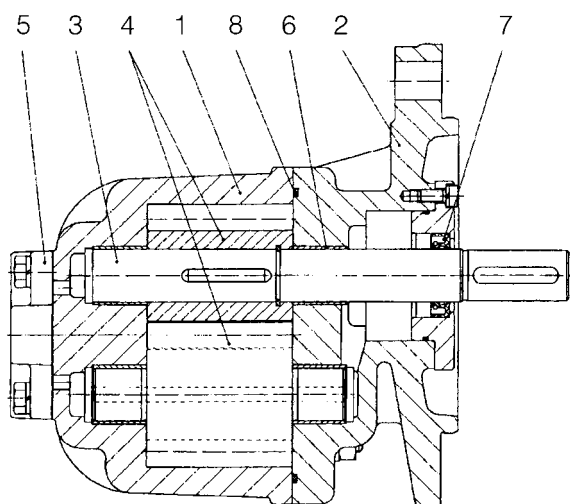

Fig. 3 **Pump without outboard bearing, special code 197**

- 1 Housing
- 2 Flange cover
- 3 Driving shaft
- 4 Gears
- 5 End cover
- 6 Bearing bush
- 7 Shaft end sealing
- 8 O-Ring

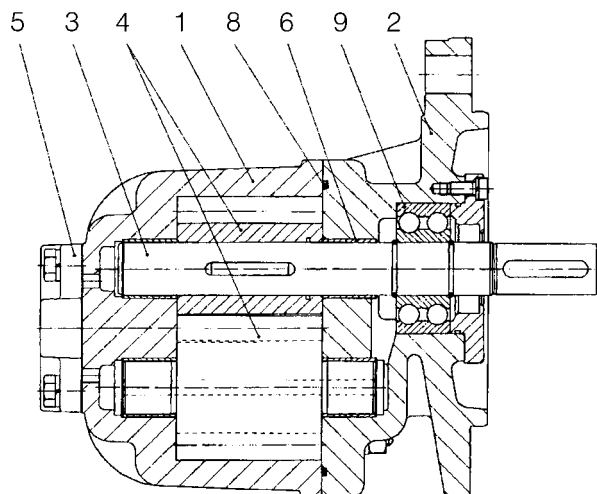
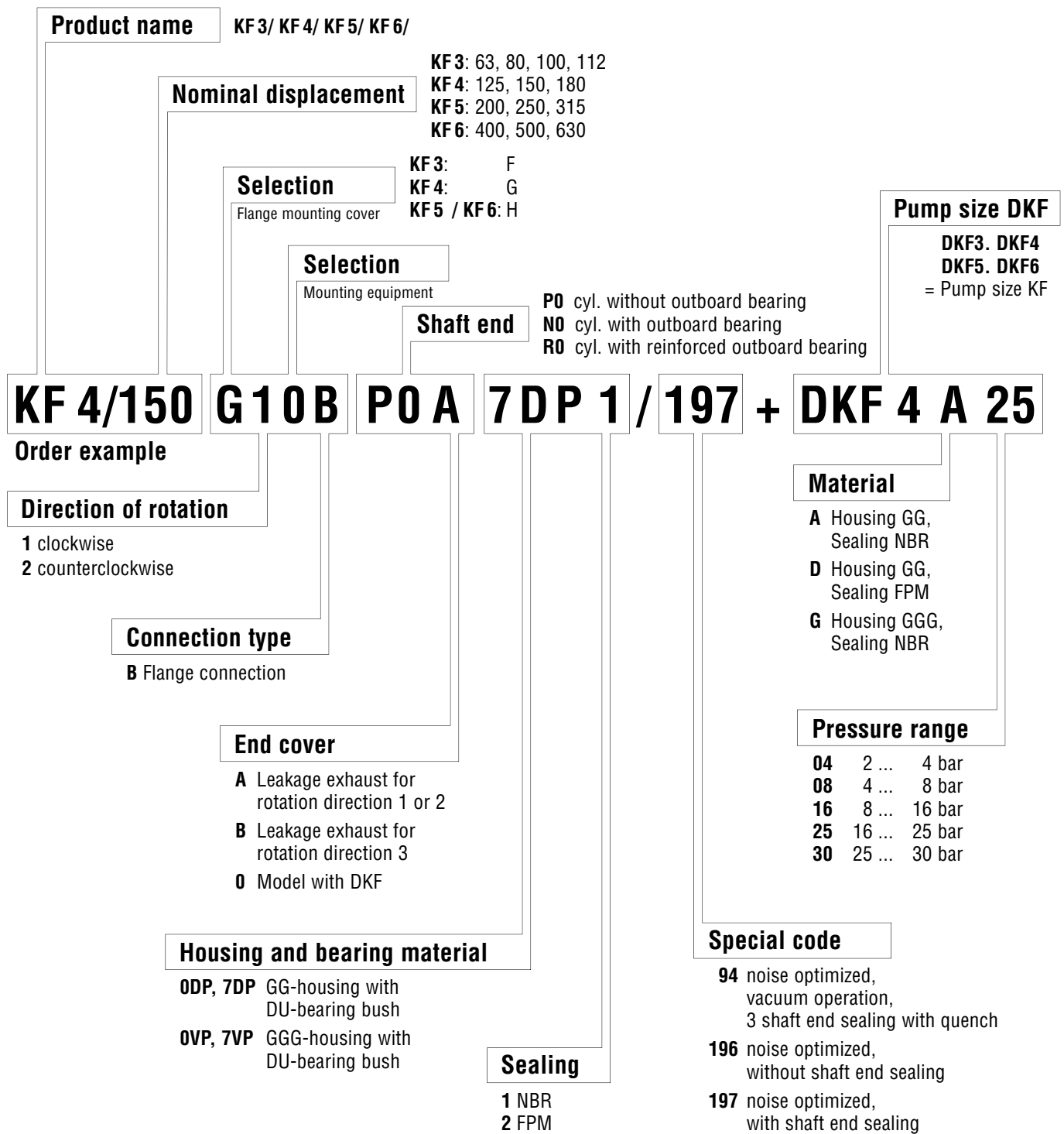

Fig. 4 **Pump with outboard bearing, special code 196**

- 1 Housing
- 2 Flange cover
- 3 Driving shaft
- 4 Gears
- 5 End cover
- 6 Bearing bush
- 8 O-Ring
- 9 Outboard bearing

Type Code



Overview of materials

Type of material and sealing*	Housing / Cover	Gears	Bearing arrangement	Shaft end sealing	O-Ring
ODP1/7DP1	EN-GJL-250 (GG 25)	Case hardening steel (1.7139)	P10	NBR	NBR
ODP2/7DP2				FPM	FPM
OVP1/7VP1	EN-GJS-400-15 (GGG 40)			NBR	NBR
OVP2/7VP2				FPM	FPM

* See nameplate on the pump: KF..

Technical Data

General specifications

Construction		External gear pump	
Branch circuit connection		Flange connection	
Installation position		Optional (<i>except special code 94</i>)	
Direction of rotation		cw or ccw	
Suction side operational pressure	$p_{e \text{ min.}}$ $p_{e \text{ max.}}$	94	0.9 bar 0.2 bar
	$p_{e \text{ min.}}$ $p_{e \text{ max.}}$	196	- 0.4 bar, Starting condition – 0.6 bar 25 bar
	$p_{e \text{ min.}}$ $p_{e \text{ max.}}$	197	- 0.4 bar, Starting condition – 0.6 bar 1 bar
Pressure side operational pressure	$p_{n \text{ max}}$	25 bar*	
RPM's	n	See overview "Nominal sizes"	
Viscosity	$v_{\text{min.}}$ $v_{\text{max.}}$	12 mm ² /s 15000 mm ² /s	
Fluid temperature	$\vartheta_{\text{min.}}$ $\vartheta_{\text{max.}}$	NBR seal	FPM seal
		- 10 °C 90 °C	- 10 °C 150 °C
Ambient temperature	$\vartheta_{u \text{ min.}}$ $\vartheta_{u \text{ max.}}$	- 20 °C 60 °C	
Permissible mediums	Transmission oil, motor oil, hydraulic oil, mineral oils <i>synthetic oil only with prior consent from Kracht GmbH</i>		
Filter	Filter fineness $\leq 60 \mu\text{m}$		

* higher pressures only with prior consent from Kracht GmbH

Overview nominal sizes

Nominal size *	Geometrical displ. volume V_g cm ³ /r	RPM's range		Perm. forces**		Sound level L_A *** dB(A)
		n_{min} 1/min	n_{max} 1/min	F_{radial} N	F_{axial} N	
3/100	100.8	200	2000	1500	200	≤ 71
3/112	112.6					≤ 71
4/125	129	200	2000	1500	200	≤ 71
4/150	153					≤ 71
4/180	184					≤ 71
5/200	204	200	2000	2000	300	≤ 71
5/250	255					≤ 71
5/315	321					≤ 71
6/400	405	200	2000	3000	500	≤ 71
6/500	505					≤ 71
6/630	629					≤ 71

* See nameplate on the pump

** Radial forces only at version with outboard bearing, on middle shaft journal

*** Measured with transmission oil, 150 mm²/s, $n = 100$ 1/min, $p = 25$ bar, oil with app. 4 % air content, measuring distance 1 m.

Sound Level

	p = 5 bar	p = 15 bar	p = 25 bar
KF 3/63	69	70	70
KF 3/80	70	71	71
KF 3/100	70	71	71
KF 3/112	71	72	72
KF 4/125	71	72	73
KF 4/150	72	73	73
KF 4/180	72	73	74
KF 5/200	75	77	77
KF 5/250	76	77	78
KF 5/315	76	78	79
KF 6/400	79	79	80
KF 6/500	81	81	82
KF 6/630	81	81	83

Sound level measured in dB(A) at 1 m distance

Sound level measured with drive motor, installation site:
Works hall, quiet sound level = 40 dB(A)

Pump assembly on rigid fastening angle,
Suction and pressure conduits: Hose

Measured with transmission oil, oil viscosity $\nu = 100 \text{ mm}^2/\text{s}$,
oil with app. 4 % air content RPM's $n = 1500 \text{ 1/min}$

Flange Pumps

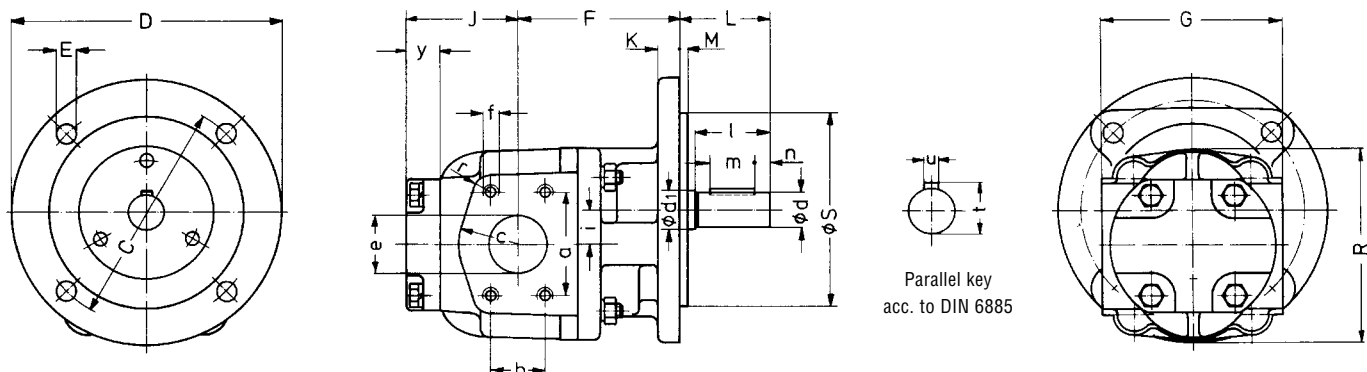

Parallel key
acc. to DIN 6885

Size	Suction and pressure connection											Shaft end								Weight kg								
	a	b	c	e	f	r	C	D	E	F	G	J	K	L	M	R	S _{h6}	i	y		d ₁	d _{k6}	l	m	n	t	u	
3/ 100 112	69.9	35.7	40	40	M10	16 deep	12	150	180	14	108	120	92	15	60	5	130	130	23	20	25	24	50	30	10	27	8	13.5
4/ 125 150 180	77.8	42.9	50	50	M12	18 deep	12	185	220	18	125	130	77	19	60	8	160	150	28.3	20	25	24	50	40	5	27	8	18.5 20 21
5/ 200 250 315	88.9	50.8	55	63							155		93								30	28	60	40	10	31	8	28 33 33
6/ 400 500 630	130.2	77.8	80	100	M16	32 deep	20	215	250	18	200	200	126	25	95	8	244	180	40	24	40	38	80	63	8	41	10	51 55 65

*KF3: Shaft end dimensions on line below are valid for P-shaft

Order designation

KF 3/. F^{1/2/3} OB N P O A B 7DP^{1/2}

KF 4/. G^{1/2/3} OB N P O A B 7DP^{1/2}

KF 5/. H^{1/2/3} OB N P O A B ODP^{1/2}

KF 6/. H^{1/2/3} OB N P O A B 7DP^{1/2}

Flange Pumps with Pressure Limitation Valve

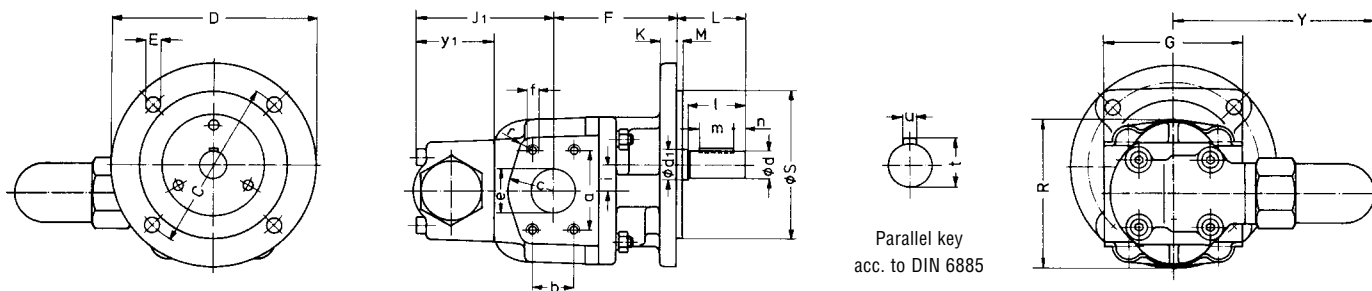

Parallel key
acc. to DIN 6885

Size	Suction and pressure connection											Shaft end										Weight kg																
	a	b	c	e	f	r	C	D	E	F	G	J ₁	K	L	M	R	S _{n6}	Y	i	y ₁	d ₁		d _{k6}	l	m	n	t	u										
3/100 112	69.9	35.7	40	40	M10	16 deep	12	150	180	14	108	120	137	15	60	5	130	130	160	23	65	25	24	50	30	10	27	8	20	19	50	30	5	21.5	6	15		
125 4/150 180	77.8	42.9	50	50	M12	18 deep	12	185	220	18	125	130	129	19	60	8	160	150	171	28.3	72	25	24	50	40	5	27	8							20	21.5	21.5	
200 5/250 315	88.9	50.8	55	63	M12	20 deep	13				155		149									30	28	60	40	10	31	8							30	35	35	
400 6/500 630	130.2	77.8	80	100	M16	32 deep	20	215	250	18	200	200	219	25	95	8	244	180	238	40	117	40	38	80	63	8	41	10								59	63	73

*KF3: Shaft end dimensions on line below are valid for P-shaft

Order designation

KF 3/. F¹/₂ OB N_P 00 7DP¹/₂ + DKF 3^A/_D/_C •

KF 4/. G¹/₂ OB N_P 00 7DP¹/₂ + DKF 4^A/_D/_C •

KF 5/. H¹/₂ OB N_P 00 0DP¹/₂ + DKF 5^A/_D/_C •

KF 6/. H¹/₂ OB N_P 00 7DP¹/₂ + DKF 6^A/_D/_C •

Performance Data

Rated Quantity	Conveyance output Q in l/min											
	Pressure p _b in bar											
	2	4	6	8	10	12	14	16	18	20	22	25
KF 3/ 63	88	87	86	85	83	82	80	79	78	76	74	72
80	113	112	110	109	107	106	104	103	101	99	98	95
100	142	141	139	137	135	133	131	129	127	125	123	120
112	159	158	156	154	152	150	148	146	144	142	140	136
KF 4/125	173	172	171	169	168	167	165	164	162	161	159	157
150	210	209	208	206	205	203	202	200	199	197	196	193
180	256	254	253	252	250	248	247	245	243	241	238	235
KF 5/200	274	273	272	270	269	267	266	264	162	261	259	257
250	347	345	343	341	339	337	335	333	330	328		
315	441	439	437	434	432	429	426	424				
KF 6/400	558	555	552	549	545	541	538	534	530	527	523	517
500	696	692	688	684	680	675	671	666	661	657		
630	871	866	861	855	849	843	837	831				

Rated Quantity	Required drive output P in kW											
	Pressure p _b in bar											
	2	4	6	8	10	12	14	16	18	20	22	25
KF 3/ 63	0.8	1.1	1.4	1.7	2.0	2.3	2.6	2.9	3.2	3.5	3.8	4.3
80	1.0	1.4	1.8	2.2	2.6	2.9	3.3	3.7	4.1	4.5	4.9	5.5
100	1.2	1.7	2.2	2.7	3.2	3.7	4.2	4.7	5.2	5.7	6.2	6.9
112	1.4	2.0	2.6	3.1	3.7	4.3	4.7	5.3	5.8	6.4	7.0	7.8
KF 4/125	1.6	2.2	2.8	3.4	4.0	4.6	5.2	5.8	6.4	7.0	7.6	8.5
150	1.9	2.6	3.3	4.0	4.8	5.5	6.2	7.0	7.7	8.4	9.2	10.6
180	2.2	3.0	3.9	4.8	5.7	6.6	7.5	8.4	9.3	10.2	11.0	12.4
KF 5/200	2.4	3.4	4.4	5.4	6.5	7.5	8.6	9.6	10.7	11.7	12.7	14.2
250	3.0	4.3	5.5	6.8	8.1	9.4	10.7	12.0	13.3	14.6		
315	3.7	5.3	6.9	8.6	10.2	11.7	13.4	15.0				
KF 6/400	5.8	7.7	9.6	11.6	13.5	15.5	17.5	19.5	21.4	23.3	25.3	28.3
500	7.3	9.8	12.3	14.7	17.2	19.6	22.0	24.5	27.0	29.4		
630	9.3	12.0	15.0	18.0	21.0	24.0	27.0	30.0				

These specifications relate to RPM's of
 $n = 1450$ 1/min and viscosity of $34 \text{ mm}^2/\text{s}$.
 Conveyance output increases with higher levels of viscosity.

Overview of our complete program

Transfer pumps

Transfer pumps for lubricating oil supply equipment, low pressure filling and feed systems, dosing and mixing systems.

Flow measurement

Gear and turbine flow meters and electronics for volume and flow metering technology in hydraulics, processing and laquering technology.

Mobile hydraulics

Single and multistage high pressure gear pumps, hydraulic motors and valves for construction machinery, vehicle-mounted machines.

Industrial hydraulics

Cetop directional control and proportional valves, hydraulic cylinders, pressure, quantity and stop valves for pipe and slab construction, hydraulic accessories for industrial hydraulics (mobile and stationary use).

With our decades of experience, we are at your side, world-wide, for the professional mastery of specific applications and complete solutions in hydraulics and process technology.



KF3-6-go/e//10.04